

## HPR40E-19K100xW

High Power 100W LED is made of hi-eff AS/TS GaInN chips with precise package technique which makes excellent heat dissipation to reach the advantages of high luminous efficiency, low decay, and long endurance. Now we have these colors available: red, green, blue, white, yellow.



### FEATURES

- Instant light
- Long operating life
- Superior ESD defense
- Low voltage DC operated
- More energy efficient than incandescent and most halogen lamps

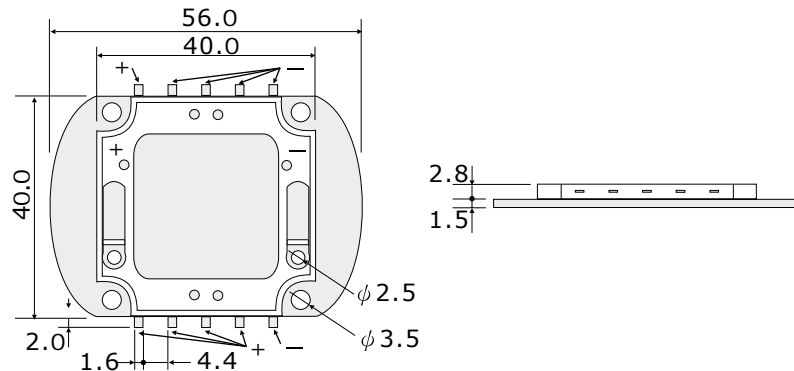

### TYPICAL APPLICATIONS

- Architectural detail lighting
- Portable flashlight
- Reading lights
- Medical applications
- LCD backlights
- Beacon lights
- Decoration lights

1. All dimensions are in millimeter.
2. Lead spacing in measured where the lead emerge from the package.
3. Protruded resin under flange is 1.5mm max.
4. Specifications are subject to change without notice.
5. Tolerance is  $\pm 0.3$ mm unless otherwise noted.
6. Driving LED without heat sinking device is forbidden.
7. It is strongly recommended that the temperature of lead be not higher than 55°C.
8. Proper current derating must be observed to maintain junction temperature below the maximum.
9. LEDs are not designed to be driven in reserve bias.
10. Warps the degree  $\pm 0.5$ mm.

### Notes

Item	Lens Color	Dice Source	Color
HPR40E-19K100BW (100W, 8000K)	Yellow Diffusion	GaInN/GaN	Cool White
HPR40E-19K100W (100W, White 6000K)			Pure White
HPR40E-19K100NW (100W, White 4000K)			Nature White
HPR40E-19K100YW (100W, Warm White 3300K)			Warm white

### Absolute Maximum Rating

PARAMETER	SYMBOL	MAX. RATING	UNIT
Continuous Forward Current	IF	2.8	A
Peak Forward Current *1	IFM	3	A
Electrostatic Discharge (HBM)	ESD	4000	V
LED Junction Temperature	Tj	135	°C
Operating Temperature	Topr	-40 ~ +110	°C
Storage Temperature	Tstg	-40 ~ +120	°C
Manual Soldering Temperature 260 °C for 5 seconds max. *2			

\*1. Duty Ratio=0.1%, Pulse Width=10us. \*2. Iron soldering high temperature will not cause damage to the dice. But be aware of the high temperature will not only make the epoxy soften but also cause the lead moving and the gold wire broken and even open. So before returning to the normal temperatures PLEASE AVOID any serious pressure on the top of epoxy and lead. \*3. We suggest using PWM (Pulse Width Modulation) for driving. \*4. It is recommended to use series as there are several 3pcs. If there are more than 5pcs, please use product with higher power.

## ELECTRICAL OPTICAL CHARACTERISTICS

Parameter	Symbol	Test condition	Min	Typ	Max	Unit
View Angle of Half Power	2q1/2	IF=2800mA		120		deg
Forward Voltage	VF		35	38		V
Color Rendering Index	CRI		85			
Thermal Resistance Junction To Case	R $\theta_{J-C}$				0.5	°C/W
Temperature Coefficient Of Forward Voltage	$\Delta V_F/\Delta T$				-2	mV/°C

## ELECTRIC-OPTICAL CHARACTERISTICS FOR LUMINOUS INTENSITY

Parameter	Symbol	Test condition	Typ	Unit
HPR40E-19K100BW (100W, 8000K)	VF	IF=2800mA	6500	lm
HPR40E-19K100W (100W, White 6000K)			6500	
HPR40E-19K100NW (100W, White 4000K)			6350	
HPR40E-19K100YW (100W, Warm White 3300K)			5850	

## ELECTRIC-OPTICAL CHARACTERISTICS FOR COLOR TEMPERATURE

Parameter	Symbol	Test condition	Typ	Unit
HPR40E-19K100BW (100W, 8000K)	CCT	IF=2800mA	8000	°K
HPR40E-19K100W (100W, White 6000K)			6000	
HPR40E-19K100NW (100W, White 4000K)			4000	
HPR40E-19K100YW (100W, Warm White 3300K)			3300	

## ENDURANCE TEST

Test Item	Reference Standard	Test Conditions	Result
Operation Life	MIL-STD-750:1026 MIL-STD-883:1005 JIS-C-7021 :B-1	Connect with a power if=1400mA Ta=Under room temperature Test Time=1,000hrs	0/22
High Temperature High Humidity Storage	MIL-STD-202:103B JIS-C-7021 :B-11	Ta=+85°C $\pm$ 5°C RH=80% ~ 85% Test Time=1,000hrs	0/22
High Temperature Storage	MIL-STD-883:1008 JIS-C-7021 :B-10	High Ta=+120°C $\pm$ 5°C Test Time=1,000hrs	0/22
Low Temperature Storage	JIS-C-7021 :B-12	Low Ta=-40°C $\pm$ 5°C Test Time=1,000hrs	0/22

## ENVIRONMENTAL TEST

Test Item	Reference Standard	Test Conditions	Result
Temperature Cycling	MIL-STD-202:107D MIL-STD-750:1051 MIL-STD-883:1010 JIS-C-7021 :A-4	-40°C ~ +25°C ~ +85°C ~ +25°C 60min 20min 60min 20min Test Time=200cycle	0/22
Thermal Shock	MIL-STD-202:107D MIL-STD-750:1051 MIL-STD-883:1010	-40°C $\pm$ 5°C ~ +110°C $\pm$ 5°C 20min 20min Test Time= 200cycle	0/22

# TYPICAL ELECTRICAL OPTICAL CHARACTERISTICS CURVES

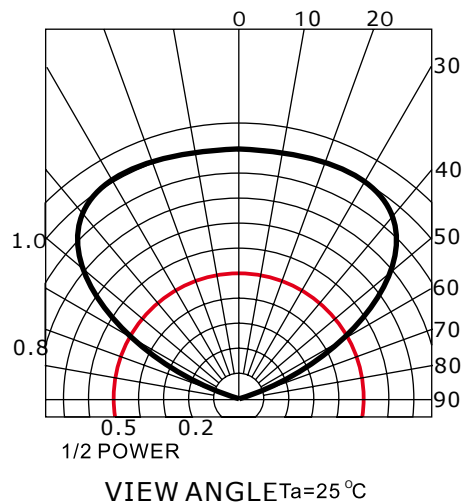
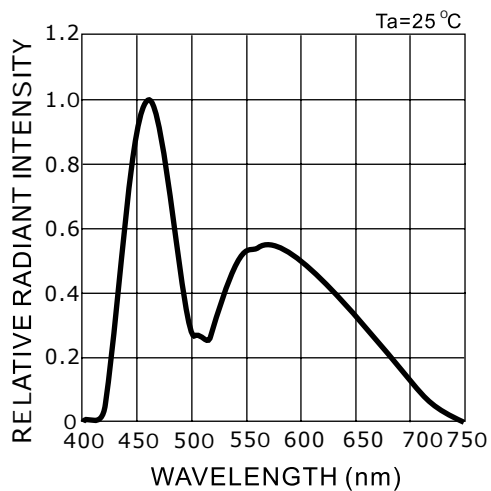
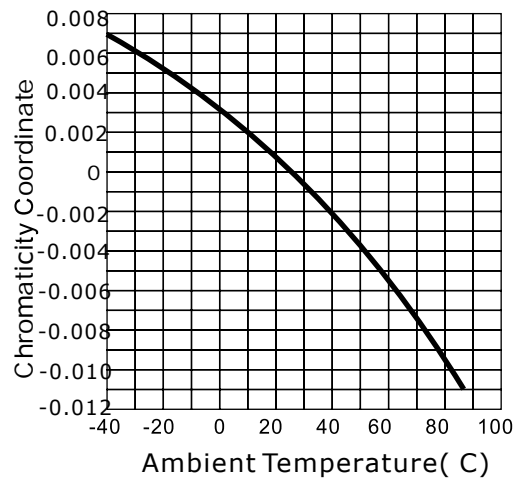
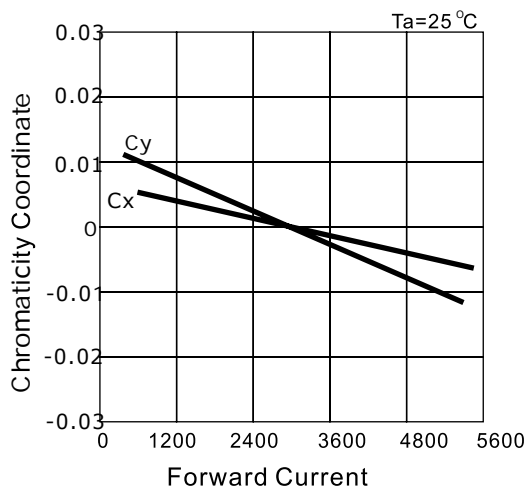
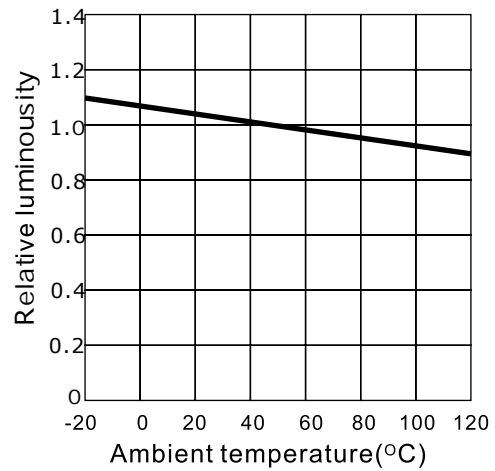
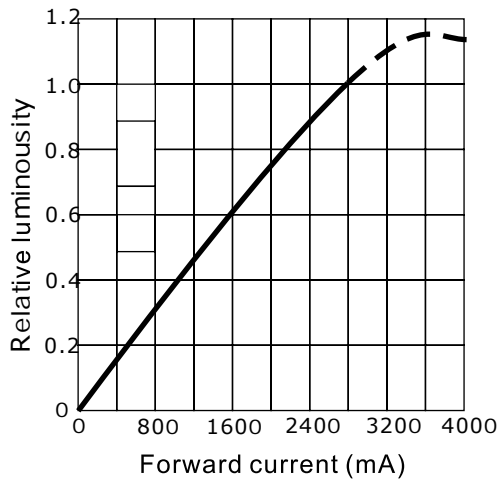
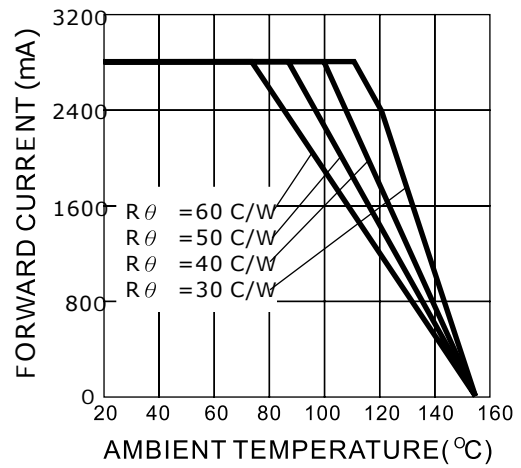
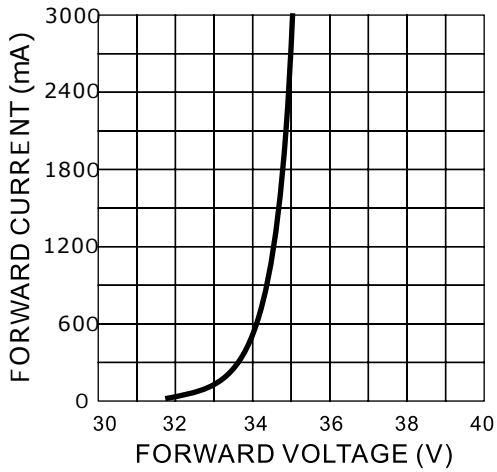

**POSITION EXPLANATION:**

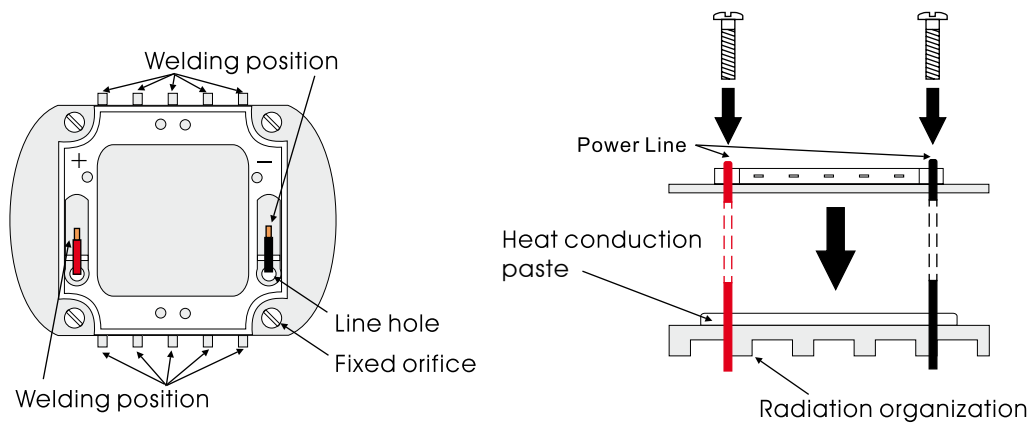

**CONCLUSION**

Huey Jann provide simple comparison table for High Power LED, you could find your request heat dissipation area from the following table.

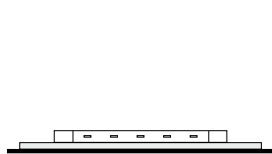

Free Convection Horizontal  
Flat Heat Dissipation-Set-up  
( Area Require mm<sup>2</sup>)



Free Convection  
Vertical Flat Heat Dissipation-Set-up  
( Area Require mm<sup>2</sup>)

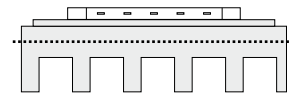

Free Convection  
Finned Heat Dissipation-Set-up  
( Area Require mm<sup>2</sup>)

**20W OPERATING INSTRUCTIONS**

1. It important to keep away the product from water, in order to avoid the product electronic characteristics to be harmful.

2. When making use of products, it is necessary to use anti-ESD devices to prevent destructive electronic characteristics.

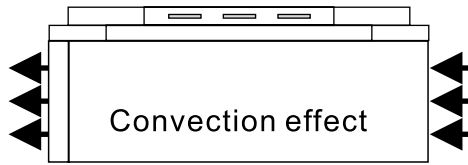

3. It should be noticed whether there is convection in design of device. Convection has to exist.

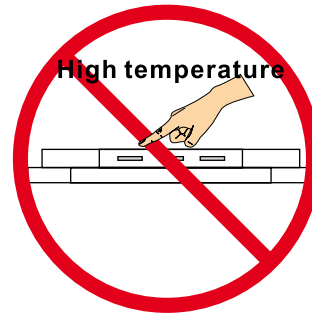

Above 150°C

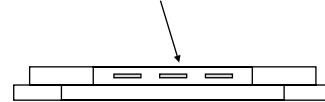

4. There is 150 °C directly from the front of 20W emitting diode. It is untouchable to prevent burning.

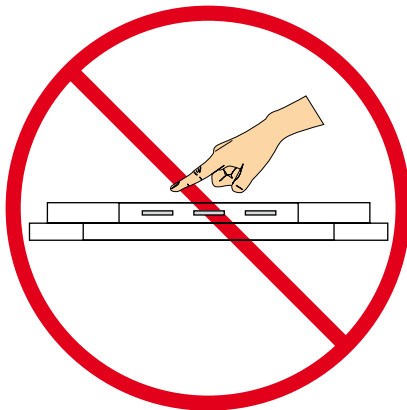

5. The material in the central top of 20W LED is soft. Therefore, it is un-squeezable and untouchable.

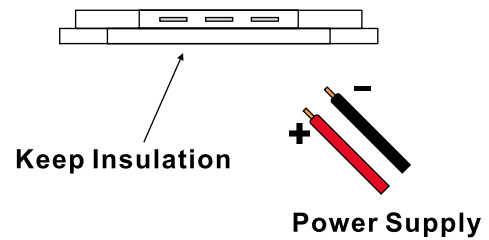

6. In the bottom of heat sink cannot be touched with neither positive nor negative pole. (Heat sink has to be insulation.)

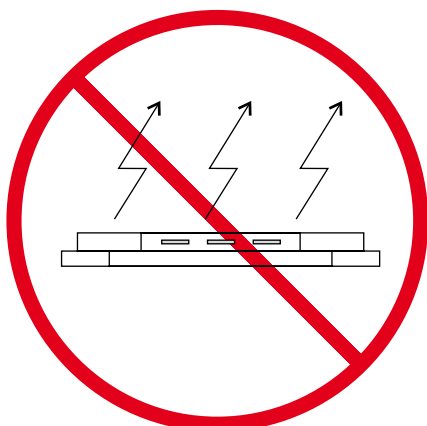

7. The product should not be light up directly without heat dissipation device.